

RC5510

RAPPER™ Family – 4 Watt Stereo Sound Driver

Features

- Up to 4W/Channel
- Drives 8Ω and 4Ω non-powered speakers
- NO-POP during power-up/power-down and mute
- Provides regulated 5V supply for sound codec, etc.
- Line Output signal to noise ratio of 85 dB
- Channel Separation, input referred (-76dB)
- Crosstalk isolation from regulator > 70dB
- Microphone amplifier with AGC -40dB dynamic range
- Sleep mode supply current typically 10μA
- Total Harmonic Distortion <0.1% THD
- Individual control pins to select mute and on/off for speaker, microphone, and regulator block
- Power Supply Rejection Ratio (PSRR, >70dB)
- Internal Thermal Shut Down

Description

The Rapper is a stereo sound driver used for driving key functions that are needed in all multimedia PCs and sound cards. These functions include directly powering speakers and headphone sets, providing a microphone pre-amplifier with AGC, and having a 12V to 5V regulator that can isolate the noise from the sound channel. Each function can be controlled individually, thus providing power saving features.

Applications

- Multimedia PC motherboards and add-in sound cards
- Companion chip to Sigma-Delta Sound Codecs
- Sound Channel back-end in Set-top boxes

Block Diagrams

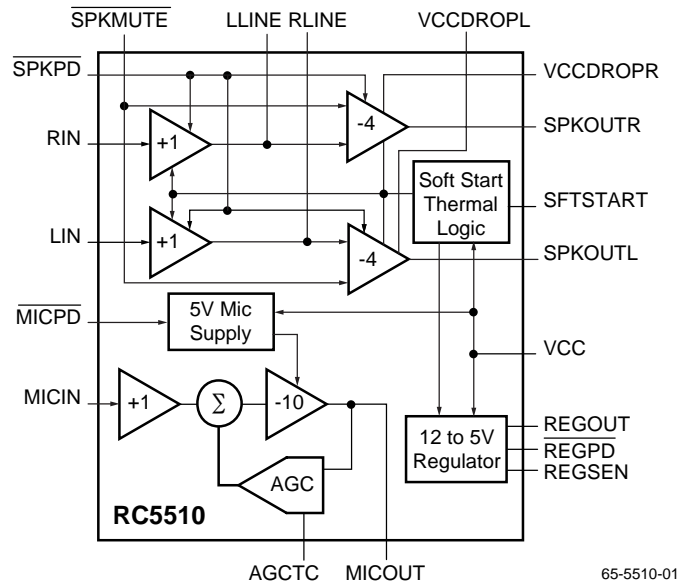

Functional Description

The Rapper Stereo Sound Driver, is an audio device that can be used on PC motherboards and add-in sound cards. It consists of stereo output drivers for headphone or speakers, a low noise microphone amplifier with AGC, and a regulator to provide a clean 5V supply. Each section can be individually put into a shut-down mode and muted by pulling the appropriate pin low.

The output drivers can deliver up to 2 Watts peak and 4 Watts peak into 8Ω and 4Ω speakers, respectively, from a 12V source. The drivers use class AB amplifiers and maintain a low bias current. The power-down function is designed to save power. To prevent popping during power down, mute the speakers via the SPKMUTE pin, then power down the amplifier section via the SPKPD pin. To prevent popping during power-up, reverse the power-down sequence. To help prevent popping signals a delay is provided to these output drivers to allow settling. The time constant is user-defined through an external capacitor (CDELAY) on the SFTSTART pin.

The microphone amplifier feeds into an AGC with a dynamic range of 40dB. An external capacitor is used to provide attack and decay features. Attack and decay times can be varied linearly by varying an external capacitor (CAD) on the AGCTC pin. The attack and decay time ratio has been set for pleasant audio quality.

The 12 V to 5V voltage regulator can provide up to 20mA of current without external components. It can provide a clean regulated voltage supply to the other devices that complete the sound channel. Use of an external transistor can boost the regulator output to 150mA or higher with the appropriate thermal precautions. The line regulation of 50dB improves the cross talk and the power supply rejection ratio of all other audio blocks that are supplied by the 5V source.

The thermal limiting circuitry activates if the chip temperature typically exceeds 150°C.

Table 1. Power-Down Configuration

L = $V_{IL} \leq 0.4V$, H = $V_{IH} \geq 2.0V$, X = Don't Care

SPKPD	MICPD	REGPD	SPKMUTE	Function
L	L	L	X	Chip Disabled
H	H	H	H	All Sections Enabled
H	L	L	L	Line Driver Enabled, Regulator and Microphone Disabled, Speaker Muted
L	H	H	X	Line Driver and Speaker Disabled, Regulator and Microphone Enabled
H	L	H	H	Microphone Only Disabled
H	H	L	H	Regulator Only Disabled

Package Pin Out

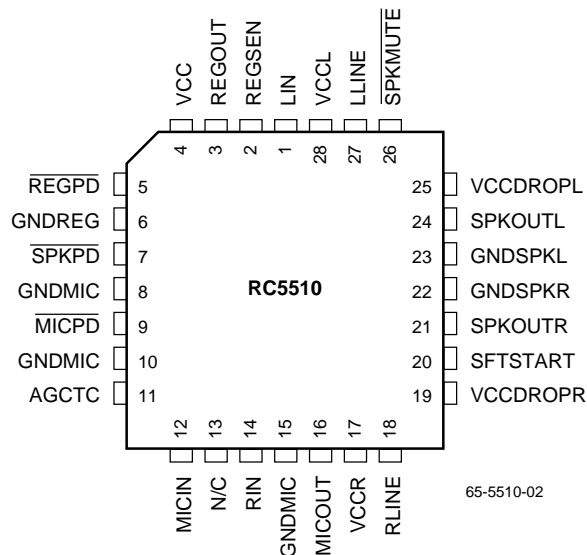

Pin Definitions

Pin Name	Pin Number	Pin Function Description
LIN	1	Left Channel Input.
REGSEN	2	Regulator Sense Point.
REGOUT	3	Regulator 5V Output.
VCC	4	12V Power Supply Input.
REGPD	5	Regulator Power-Down.
GNDREG	6	Regulator Ground.
SPKPD	7	Speaker and Line Driver Power-Down.
GNDMIC	8, 10, 15	Microphone Ground.
MICPD	9	Microphone Power-Down.
AGCTC	11	Attack and Decay Capacitor Pin.
MICIN	12	Microphone Input.
N/C	13	No Connect.
RIN	14	Right Channel Input.
MICOUT	16	Microphone Output.
VCCR	17	Right Speaker Supply.
RLINE	18	Right Line Driver Output.
VCCDROPR	19	Right Speaker Power Drop Supply.
SFTSTART	20	Soft Start Timing Capacitor.
SPKOUTR	21	Right Speaker Output.
GNDSPKR	22	Right Speaker Ground.
GNDSPKL	23	Left Speaker Ground.
SPKOUTL	24	Left Speaker Output.
VCCDROPL	25	Left Speaker Power Drop Supply.
SPKMUTE	26	Speaker Mute.
LLINE	27	Left Line Driver Output.
VCCL	28	Left Speaker Supply.

Absolute Maximum Ratings

(beyond which the device may be damaged)¹

Parameter		Min.	Typ.	Max.	Units
VCC	Power supply voltage			13.2	V

Note:

1. Functional operation under any of these conditions is NOT implied.

Operating Conditions

Parameter		Conditions	Min.	Typ.	Max.	Units
VCC VCCR VCCL	Power Supply		11.8	12	12.8	V
VCCDROPR VCCDROPL	Right and Left Power Drop Supplies	RDROP = 2Ω (See Figure 1)	11.2	12	12.8	V
V _{IH}	Input Voltage Logic High		2			V
V _{IL}	Input Voltage Logic Low				0.4	V
	Ambient Temperature		0		70	°C
T _c	Maximum Operation Die Temperature	Overthermal Protection		150		°C
I _{total}	Power Supply Current	No load		19	25	mA
I _{SD}	Shut-Down Current	SPKPD, MICPD, REGPD = V _{IL}		10	75	μA
ESD	ESD Threshold on Signal Pins		2000			V

DC Electrical Characteristics

VCC = 12V ± 6%, unless otherwise specified.

Parameter		Conditions	Min.	Typ.	Max.	Units
Line Driver		f = 1KHz, RL = 600Ω unless otherwise specified				
Z _{in}	Input Impedance			10		KΩ
A _v	Voltage Gain	V _{in} = 1 V _{rms}	0.95	1.0	1.05	V/V
L&R A _v	Left and Right Gain Matching	V _{out} = 4V _{p-p}		0.3		%
V _o	Output Voltage	RL = 600Ω		±4		V
THD	Total Harmonic Distortion	V _{out} = 4V _{p-p}		0.01		%
PSRR	Power Supply Rejection Ratio	f = 100Hz, ΔV _{cc} = 0.85V _{rms}	80	86		dB
SNR	Signal to Noise Ratio	V _{in} = 2.8V _{rms}		85		dB
Speaker Driver		f = 1KHz, RL = 8Ω unless otherwise specified				
I _{spk}	Speaker Driver Supply Current	V _{in} = 0V		9		mA
Z _{in}	Input Impedance		100			KΩ
A _v	Voltage Gain	V _{in} = 1 V _{rms}	-3.80	-4.0	-4.20	V/V
L&R A _v	Left and Right Gain Matching	V _{out} = 4V _{p-p}		0.5		%
V _o	Output Voltage	RL = 8Ω, VCC = 12V		±4		V _{pK}

DC Electrical Characteristics (continued)

VCC = 12V ± 6%, unless otherwise specified.

Parameter		Conditions	Min.	Typ.	Max.	Units
Vo	Output Voltage	RL = 4Ω, VCC = 12V		±4		VpK
SNR	Signal to Noise Ratio	Input Referenced		85		dB
Po	Power Output Per Channel Peak	RL = 4Ω, VCC = 12V (See Fig. 1)		4		W
CS	Channel Separation L/R Input Referenced	Vin = 0.5 Vrms	66			dB
XTALK	Cross Talk Mic to L/R Input Referenced	Vin = 1m Vrms	90			dB
XTALK	Cross Talk Reg to L/R Input Referenced	Vin = 0.5 Vrms	90			dB
THD	Total Harmonic Distortion	fo = 1KHz, Po = 50mW		0.1		%
Noise		20Hz to 20KHz, A-Weighted		4		uVrms
PSRR	Power Supply Rejection Ratio Input Referenced	f = 100Hz, Vin = 0.85Vrms	70	80		dB
Microphone Amplifier		f = 1KHz, RL = 10KΩ unless otherwise specified				
Imicamp	Microphone Amp Supply Current	Vin = 0V, max gain		4		mA
Zin1	First Amp Input Impedance			4.5		KΩ
VOL+	Positive Swing	RL = ∞	2.0			V
VOL-	Negative Swing	RL = ∞	2.0			V
Av1	First Amp Gain			1		V/V
Av2	Second Amp Gain			-10		V/V
AGC	AGC Dynamic Range			40		dB
THD	Total Harmonic Distortion	Vin = 5mVp-p, AGC off		0.1		%
Noise		20Hz to 20KHz, A-Weighted		8		uVrms
XTALK	XTALK from other blocks at MICOUT	Vin = 1Vrms at 1KHz	70			dB
PSRR	Input Referenced	f = 100Hz, Vin = 0.85Vrms	70			dB
Voltage Regulator						
Ireg	Voltage Regulator Supply Current			1.5		mA
Vreg	Regulator Voltage		4.75	5	5.25	V
Tc	Tempco			0.5		mV/°C
	Line Regulation			3		mV/V
	Load Regulation			2		mV/mA
Io	Output Current	Source		20		mA
		Source With External 2N2222		150		mA
		Sink		100		μA
Soft Start						
Delay	Anti-Pop Ramp-Up and Ramp-Down time	No Pop condition CDELAY = 20μF on SFTSTART		2		sec

Applications Discussion

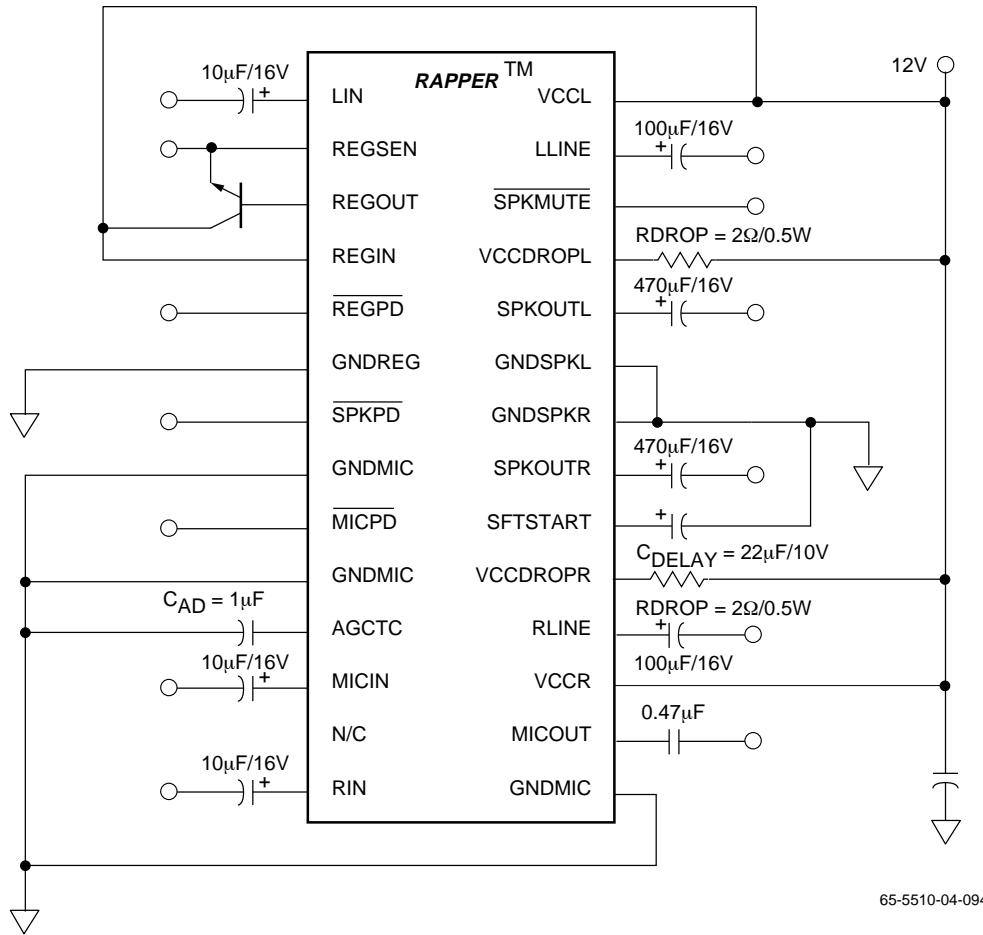

65-5510-04-094

Notes:
 4 Watt power represents the peak of the audio level and cannot be sustained without correct package thermal considerations. However, the average audio signal with peaks of 4 Watts can be sustained by the RC5510 without extra thermal considerations.

Figure 1. RAPPER™ RC5510, 4 Ohm Speaker, 4 Watt Application with External Pass Transistor for Voltage Regulator

This circuit schematic represents the concept of the application. The applications note details component values for different performance scenarios.

Mechanical Dimensions – 28 Lead PLCC Package

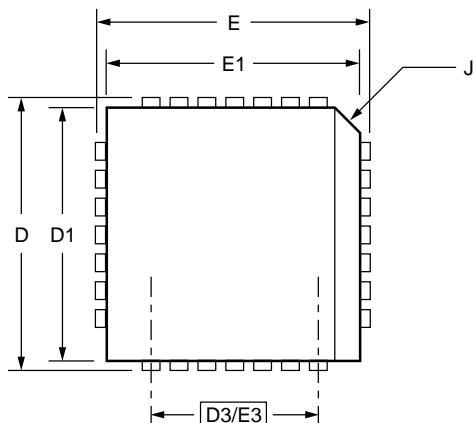

Symbol	Inches		Millimeters		Notes
	Min.	Max.	Min.	Max.	
A	.165	.180	4.19	4.57	
A1	.090	.120	2.29	3.04	
A2	.020		.51		
B	.013	.021	.33	.54	
B1	.026	.032	.66	.81	
D/E	.485	.495	12.32	12.57	
D1/E1	.450	.456	11.43	11.58	
D3/E3	.300 BSC		7.62 BSC		
e	.050 BSC		1.27 BSC		
J	.042	.048	1.07	1.22	8
ND/NE	7		7		
N	28		28		
ccc		.004		0.10	

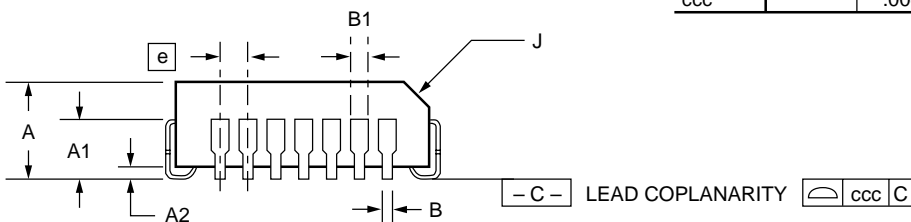

Notes:

1. Cavity mismatch = .004 (0.10mm)
2. Cavity frame offset = .002 (0.05mm) excluding leadframe tolerances.
3. Mold protrusions: Parting Line = .006 (0.15mm), Top or Bottom = .001 (0.025mm)
4. Variation in lead position = .005 (0.13mm)
5. Shoulder intrusions & protrusions: Intrusions = .002 (0.05mm), Protrusions = .003 (0.08mm)
6. Package warpage, WARP FACTOR = $2.5 = \frac{\text{WARP (mils)}}{\text{PACKAGE LENGTH (inches)}}$
7. Ejector pin depth = .010 (0.25mm) maximum.
8. Corner and edge chamfer = 45°C.

Ordering Information

Product Number	Package
RC5510V	28 PLCC

LIFE SUPPORT POLICY

FAIRCHILD'S PRODUCTS ARE NOT AUTHORIZED FOR USE AS CRITICAL COMPONENTS IN LIFE SUPPORT DEVICES OR SYSTEMS WITHOUT THE EXPRESS WRITTEN APPROVAL OF THE PRESIDENT OF FAIRCHILD SEMICONDUCTOR CORPORATION. As used herein:

1. Life support devices or systems are devices or systems which, (a) are intended for surgical implant into the body, or (b) support or sustain life, and (c) whose failure to perform when properly used in accordance with instructions for use provided in the labeling, can be reasonably expected to result in a significant injury of the user.
2. A critical component in any component of a life support device or system whose failure to perform can be reasonably expected to cause the failure of the life support device or system, or to affect its safety or effectiveness.